

IDEAL 4860

IDEAL 5260

IDEAL 6660





- DE** Bitte lesen Sie vor Inbetriebnahme der Maschine unbedingt diese Betriebsanleitung und beachten Sie die Sicherheitshinweise. Die Betriebsanleitung muss jederzeit verfügbar sein.
- EN** Please read these operating instructions before putting the machine into operation and observe the safety precautions. The operating instructions must always be available.
- FR** Nous vous prions de lire attentivement le mode d'emploi avant d'utiliser la machine, et attirons votre attention sur les consignes de sécurité. Les instructions d'utilisation et les consignes de sécurité doivent toujours être disponibles. Les instructions d'utilisation et les consi.
- NL** Leest u voor de ingebruik name van het apparaat a.u.b. deze gebruiksaanwijzing goed door en neemt u de veiligheidsinstructies n acht. De gebruiksaanwijzing en de veiligheids-voorschriften moeten altijd binnen handbereik zijn.
- IT** Per favore legga questo manuale di istruzione prima di mettere in funzione il distruggidocumenti e osservi le regole di sicurezza. Le istruzioni d'uso devono essere sempre disponibili.
- ES** Le recomendamos lea las instrucciones antes de poner en funcionamiento esta máquina y cumpla las normas de seguridad. Las instrucciones de servicio y seguridad deben estar siempre disponibles.
- SV** Läs igenom denna bruksanvisning innan ni startar maskinen. Var noga med säkerhetsföreskrifterna. Instruktionsmanualen måste alltid finnas tillgänglig.
- FI** Lue nämä käyttö-ohjeet läpi ennenkuin käynnistät laitteen !
Noudata turvaohjeita. Käyttöohjeiden on oltava aina saatavilla.
- NO** Lees gjennom denne bruksanvisningen før De tar i bruk maskinen
Vær oppmerksom på sikkerhetsforskriftene. Operatormanualen må alltid være tilgjengelig.
- PL** Proszę uważnie przeczytać instrukcję obsługi przed uruchomieniem urządzenia i stosować się do przepisów bezpieczeństwa. Instrukcje obsługi muszą być zawsze dostępne.
- RU** Пожалуйста, прочитайте инструкцию по эксплуатации перед установкой аппарата, соблюдайте технику безопасности. Инструкция по эксплуатации должна находиться в доступном для пользователя месте.
- HU** A gép üzembe helyezésé előtt figyelmesen olvassa el a kezelési utasítást és tartsa be a biztonsági előírásokat. Kezelési utasításnak mindig elérhetőnek kell lennie.
- TR** Lütfen makineyi çalıştırmadan önce bu kullanma talimatlarını dikkatli bir şekilde okuyunuz ve belirtilen güvenli k önlemlerine uyunuz. Kullanma Talimatları her zaman kullanıma hazır olmalıdır.
- DA** Før installation af maskinen bedes De venligst læse brugervejledningen og være opmærksom på sikkerhedsanvisningerne. Brugervejledningen skal altid være tilgængelig.
- CS** Prosim přečtete si instrukce k obsluze a dodržujte bezpečnostní upozornění. Návod k obsluze musí být vždy dostupný.
- PT** Por favor leiam o manual de instruções antes de colocar a máquina em operação e vejã as precauções de segurança. As instruções de operação deverão estar sempre disponíveis.
- EL** ΠΑΡΑΚΑΛΩ ΔΙΑΒΑΣΤΕ ΤΙΣ ΟΔΗΓΙΕΣ ΧΡΗΣΕΩΣ ΚΑΙ ΤΙΣ ΠΡΟΦΥΛΑΞΕΙΣ ΑΣΦΑΛΕΙΑΣ ΠΡΙΝ ΒΑΛΕΤΕ ΤΟ ΜΗΧΑΝΗΜΑ ΣΕ ΛΕΙΤΟΥΡΓΙΑ. ΟΙ ΟΔΗΓΙΕΣ ΧΡΗΣΗΣ ΠΡΕΠΕΙ ΝΑ ΕΙΝΑΙ ΠΑΝΤΑ ΔΙΑΘΕΣΙΜΕΣ.
- SL** Prosim preberite navodila za uporabo ter upoštevajte varnostna opozorila preden zaženete napravo. Navodila naj bodo vedno pri roki.
- SK** Starostlivo si preštudujte tento návod na obsluhu pred uvedením stroja do prevádzky a najmä bezpečnostné predpisy. Držte tento návod na obsluhu na dostupnom mieste.
- ET** Palun lugege enne masina käivitamist käesolevat kasutusjuhendit ning järgige ohutusnõudeid. Kasutusjuhend peab alati käepärast olema.
- ZH** 使用機器前，請閱讀此操作指引，並留意安全守則
操作手册必须是经常可用的。
- AR** والامان الوقاية تعليمات ملاحظة نرجو كما الماكينة بتشغيل البدء قبل التشغيل تعليمات قراءة نرجو لا بد من وجود تعليمات التشغيل دائما



- DE** Keine Bedienung durch Kinder!
EN Children must not operate the machine!
FR Pas d'utilisation par un enfant!
NL Geen bediening door kinderen!
IT Non lasciare utilizzare il tagliacarte a bambini!
ES No dejar que la utilicen los niños!
SV Installera maskinen utom räckhåll för barn!
FI Asentakaa laite lasten ulottumattomiin !
NO Installer maskinen utenfor rekkevidde for barn!
PL Dzieciom nie wolno obsługiwać urządzenia !
RU Не допускайте детей к пользованию аппаратом!
HU Gyerekek a gépet nem kezelhetik
TR Makinayı Çocuklar Kullanmamalıdır.
DA Må kun betjenes af voksne
CS Stroj nesmí být obsluhován dětmi!
PT As crianças não devem trabalhar com a máquina!
EL ΑΠΑΓΟΡΕΥΕΤΑΙ Η ΧΡΗΣΗ ΑΠΟ ΠΑΙΔΙΑ.
SL Otroci ne smejo uporabljati naprave
SK So strojom nesmú pracovať deti!
ET Lapsed ei tohi masinat kasutada!
ZH 勿让儿童使用机器!
AR يجب علي الأطفال عدم تشغيل الماكينة.



- DE** Nicht unter das Messer fassen!
EN Do not reach beneath the blade!
FR Ne pas passer les mains sous la lame!
NL Niet met de handen onder het mes komen!
IT Non toccare la lama nella parte inferiore!
ES ¡No tocar debajo de la cuchilla!
SV Sträck inte in handen under kniven!
FI Älä laita kättäsi terän alle !
NO Plasser aldri hender ol. under kniven !
PL Nie wkładać rąk pod noże!
RU Избегайте попадания рук под лезвие!
HU Ne nyúljon a kés alá!
TR Elinizi bıçağın altına sokmayınız!
DA Stik ikke hænderne ind under knivbladet!
CS Nesahejte pod ostrí nože!
PT Não tocar na parte inferior da faca!
EL ΜΗΝ ΑΓΓΙΖΕΤΕ ΤΟ ΚΑΤΩ ΜΕΡΟΣ ΤΗΣ ΛΕΠΙΔΑΣ!
SL Ne segajte z roko pod rezilo!
SK Nevkladajte ruky pod nôž!
ET Ärge pange kätt tera alla!
ZH 请勿接触刀具的下方。
AR لا تصل تحت السكين



- DE** Messer nie lose liegen lassen!
Messer nur mit Messerwechsellvorrichtung oder im Messertransportkasten befördern!
(siehe Seite 30 und 32).
⚠ **Warnung!** Verletzungsgefahr!
- EN** Never leave the blade unattended!
Do not extract or transport the blade without protection!
(See page 30 and 32).
⚠ **Danger!** Risk of injury!
- FR** Ne jamais laisser la lame sans protections !
Elle ne doit être démontée qu'à l' aide du dispositif de changement de lame (cf. page 30 et 32), ou transportée dans son étui en bois !
⚠ **Danger!** Risques de coupures !
- NL** Laat nooit de messen alleen achter.
Transporteer de messen niet zonder de houten bescherming (zie pagina 30 en 32).
⚠ **Waarschuwing!** Opgelet voor ongevallen!
- IT** Non lasciare mai la lama incustodita. Non rimuovere o trasportare la lama senza protezione. (Vedi pagina 30 e 32).
⚠ **Attenzione!** Rischio di infortunio!
- ES** ¡No quitar la cuchilla sin prestar atención. No desmontar no transportar la cuchilla sin protección! (vérase pág. 30 y 32)
⚠ ¡**Advertencia!** ¡Peligro de hacerse daño!
- SV** Lämna aldrig maskinen obemannad. Ta inte ur eller transportera kniven utan skydd. (se sid 30 och 32).
⚠ **Skaderisk!**
- FI** Käsittelle terää aina varoen. Älä siirrä tai kuljeta terää ilman suojaa ! (katso sivu 30 ja 32)
⚠ **Loukkaantumisen vaara !**
- NO** La aldri kniven ligge ubeskyttet. Ta aldri ut kniven eller transporter den uten beskyttelse (Se side 30 og 32)
⚠ **FARE !** Muligheter for skade !
- PL** Nigdy nie pozostawiać noży bez nadzoru.
Nie wyciągać lub transportować noży bez osłon!
(zobacz strona 30 i 32).
⚠ **Ryzyko skaleczenia sie!**
- RU** Не оставляйте открытое лезвие без присмотра! Не пытайтесь извлечь или транспортировать лезвие без специальных мер предосторожности!
(См. страницы 30 и 32)
⚠ **Соблюдайте выше перечисленные правила для избежания травм!**
- HU** Soha ne hagyja a kést őrizetlenül!
Ne vegye ki vagy ne szállítsa a kést védőtok nélkül!
(Lásd 30. és 32. oldal)
⚠ **Veszély!** Sérülésveszély!
- TR** Bıçağı hiçbir zaman gözetimsiz bırakmayınız!
Bıçağı muhafazasız olarak yerinden çıkartmayınız veya taşımayınız! (Sayfa 30 ve 32'e bakınız)
⚠ **Dikkat!** Yaralanma riski!



- DA** Knivbladet må aldrig efterlades uden opsyn.
Forsøg ikke at afmontere eller transportere knivbladet uden beskyttelse! (Se side 30 og 32)
⚠ **FARE! Risiko for legemlig beskadigelse.**
- CS** Nikdy nenechávejte nůž bez krytu.
Nikdy nevyjímejte nebo neprepravujte nůž bez ochranného krytu (viz. strany 30 a 32)
⚠ **Nebezpečí! Riskujete zranění**
- PT** Deixar a faca sempre em local seguro!
Não retirar ou transportar a faca sem protecção!
(Ver pág. 30 e 32)
⚠ **Perigo! Risco de dano!**
- EL** ΜΗΝ ΑΦΗΝΕΤΕ ΤΗΝ ΛΕΠΙΔΑ ΑΝΕΠΙΤΗΡΗΤΗ!
ΜΗΝ ΑΛΛΑΖΕΤΕ Ή ΜΕΤΑΦΕΡΕΤΕ ΤΗΝ ΛΕΠΙΔΑ ΧΩΡΙΣ ΠΡΟΦΥΛΑΞΗ (Δείτε σχετικά στις σελίδες 30 & 32)
⚠ **ΠΡΟΣΟΧΗ ! ΚΙΝΔΥΝΟΣ ΤΡΑΥΜΑΤΙΣΜΟΥ !**
- SL** Nikoli ne puščajte rezila nazaščitenega. Nikoli ne prenašajte rezilo brez zaščite. (glej stran 30 in 32).
⚠ **Pozor! Nevarnost poškodbe.**
- SK** Nenechávajúce nůž nechránený (nezabezpečený)!
Nevyberajte alebo netransportujte nůž bez ochrany (vid s. 30 a 32)
⚠ **! Riziko úrazu !**
- ET** Ärge jätke löiketera kunagi järelevalveta!
Ärge pikendage ega teisaldage tera kaitseseadmeteta!
(Vt lk 30 ja 32)
⚠ **Oht! Vigastuste oht!**
- ZH** 在没人留意的情况下，请勿离开刀具。
在没有保护的情况下，请勿取出或运送刀具！（参阅第 30 和 32 页）。
⚠ 危险！可引致受伤！
- AR** لا تترك السكين بدون اهتمام
لا تخرج أو تنقل السكين بدون حماية (أنظر صفحة 30 و 32)
⚠ خطر! التعرض للآذى

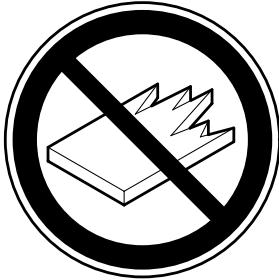

- DE** Keine harten und splitternden Materialien schneiden!
EN Do not cut hard materials or materials which may splinter!
FR La coupe de matériaux trop durs ou risquant des projections est interdite !
NL Snij geen harde materialen of materiaal dat kan splinteren!
IT Utilizzare il tagliacarte esclusivamente per il taglio di risme di carta o materiali analoghi!
ES ¡No cortar materiales duros o materiales que puedan astillarse!
SV Försör inte hårt material eller material som kan splittras!
FI Asentakaa laite lasten ulottumattomiin !
NO Ikke kutt hardt metall eller materiale som kan splintre !
PL Nie ciąć twardych materiałów lub materiałów, które mogą ulec odprysnięciu!
RU Данный резак не предназначен для резки твердых материалов или материалов, которые могут расщепляться!
HU Ne vágjon kemény vagy olyan anyagot, amely repedhet!
TR Sert veya parçalanabilecek malzemeleri kesmeyiniz!
DA Der må ikke skæres i hårde materialer eller i materialer, der kan splintre!
CS Neřežte tvrdý materiál, při kterém mohou ustřelovat ostré úlomky!
PT Não cortar materiais duros ou materiais que possam lascar!
EL ΜΗΝ ΚΟΒΕΤΕ ΣΚΛΗΡΑ ΥΛΙΚΑ Ή ΥΛΙΚΑ ΠΟΥ ΘΡΥΜΜΑΤΙΖΟΝΤΑΙ!
SL Nikoli ne režite trdih materialov ali materialov, ki se lahko razcepijo.
SK Nerežte tvrdé materiály, alebo materiály, z ktorých môžu vystrelovať ostré úlomky.
ET Ärge lõigake kõvasid materjale ega materjale, mis võivad pilbasteks puruneda!
ZH 请勿切割坚硬或可裂成碎片物料。
AR لا تقطع الأشياء الصلبة أو الأشياء التي يتطاير منها شظايا!

• Safety precautions •

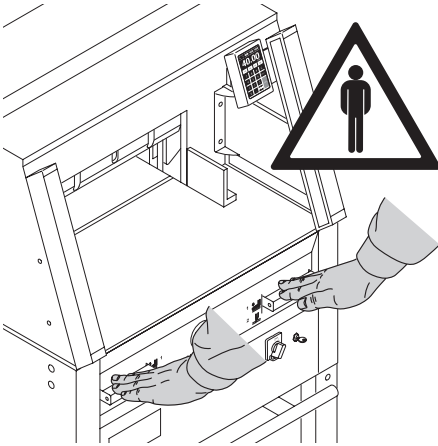

The machine is designed for cutting stacks of paper to a specified size. This machine is constructed for "one-man operation" only!
⚠ **Warning!** Clips or similar damage the cutting blade.

Disconnect from the mains before starting any service work or before removing the panels!

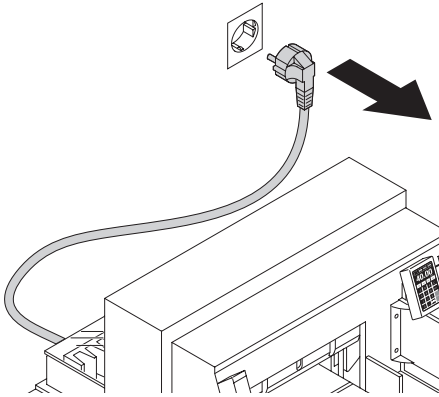

Replacement of blade and cutting stick may be performed only when the main switch is switched off!

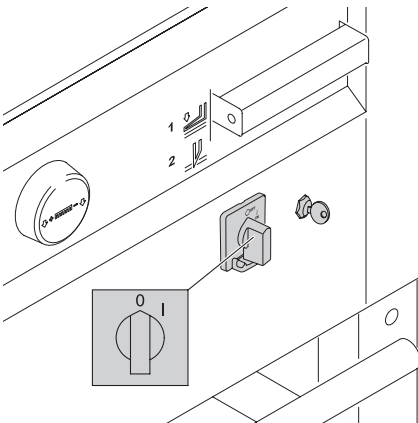

IDEAL 4860 • IDEAL 5260 • IDEAL 6660

All components which could endanger the operator are covered by a guard!

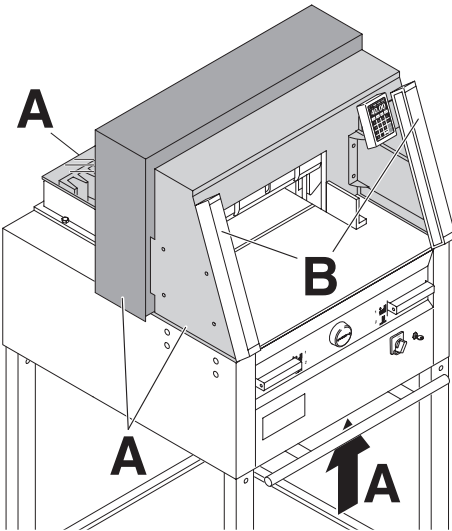

Operating the machine without safety device is forbidden!
(Rear screwed safety guard (A) and panel (B)).

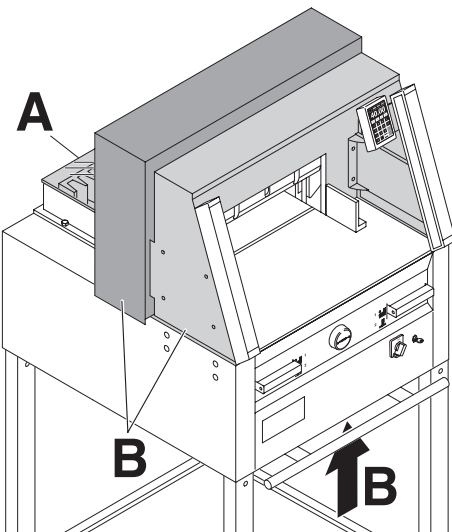

• Safety precautions •

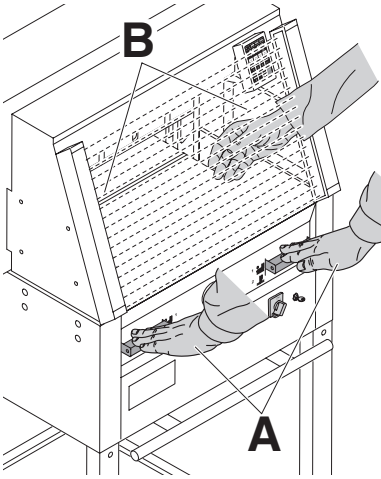

The cutting action, which is dangerous to the operator, is

- protected by a two-handed control system (A)
- and safety beam guard (B).

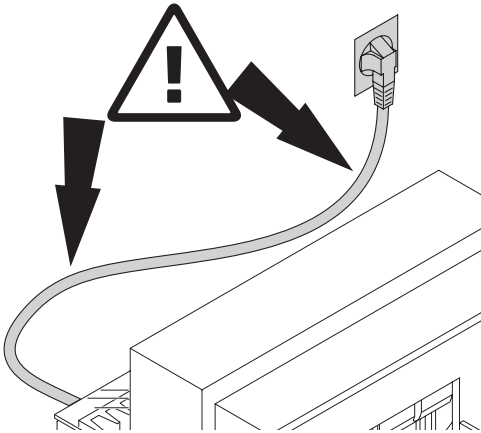

Protect mains cable against heat, oil and sharp edges!

IDEAL 4860 • IDEAL 5260 • IDEAL 6660

230V / 10A min
115V / 15A min

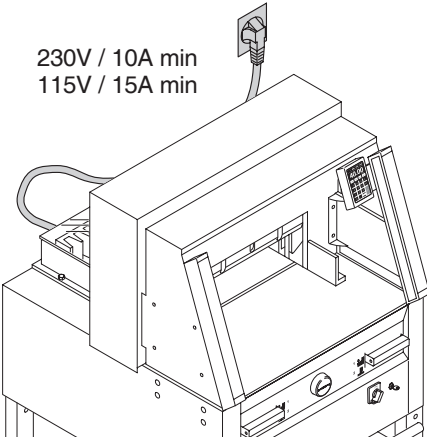

Connect the power cord to a single phase socket.

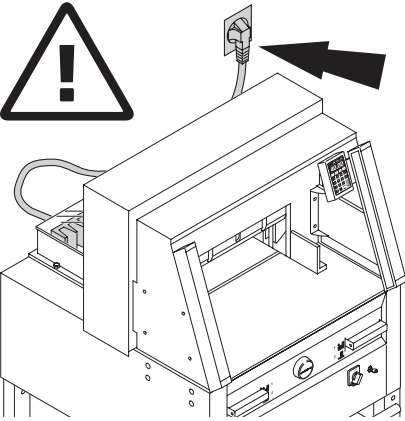

Ensure free access to mains!

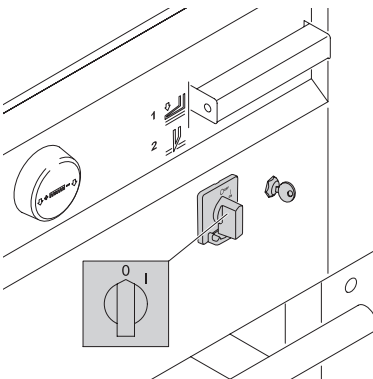

When not in use for a longer period switch off.
(Main switch to "0").

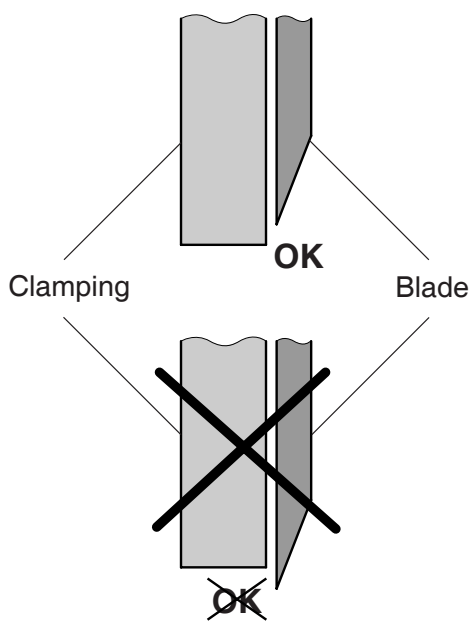

⚠ Danger!
Blade must always be covered by the pressing bar.

IDEAL 4860 • IDEAL 5260 • IDEAL 6660

Remove the stand from the wooden pallet.

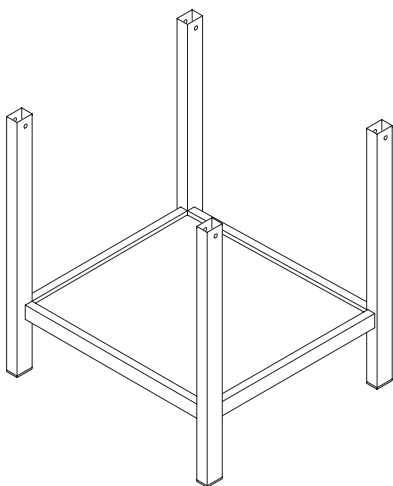

4 strong people are required to lift the machine from the pallet and place it on the stand. Secure with 4 screws (A). Put the shelf (B) on the stand. (Parts and tools are in the tool set (C)).

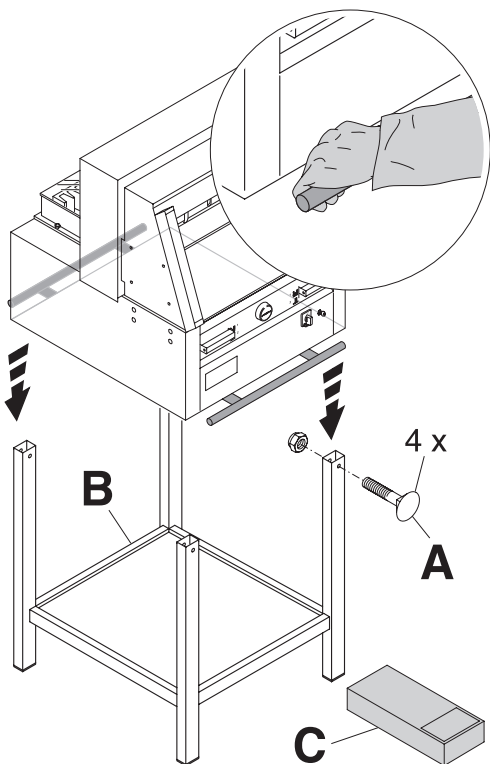

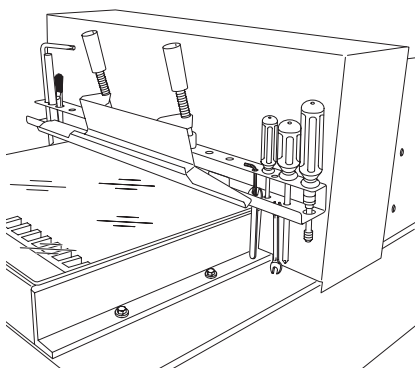

Tools can be kept in the holder provided .

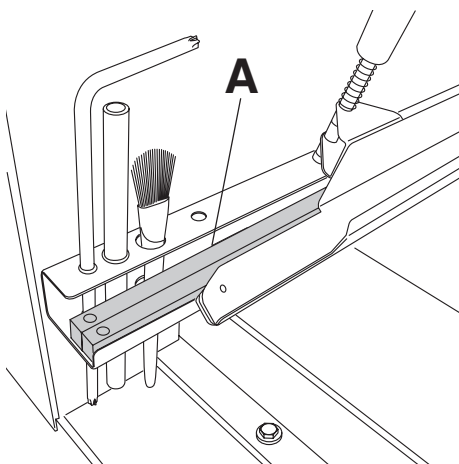

Cutting sticks (**A**) can be put in the tool holder

IDEAL 4860 • IDEAL 5260 • IDEAL 6660

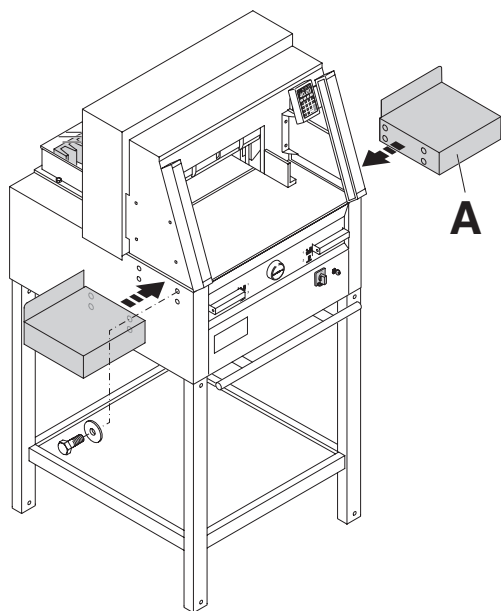

Side tables (A), left and right are available as an option (Nr. 9000 528).

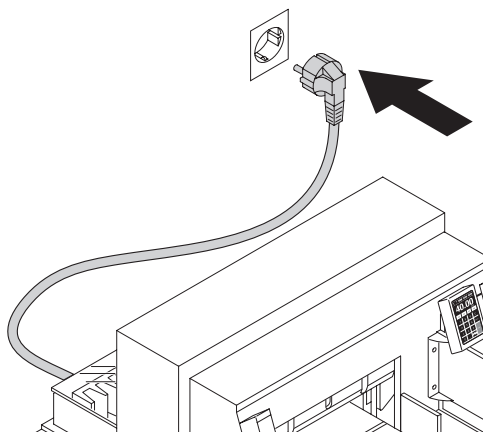

Plug into socket.
The machine must be connected directly to the socket.

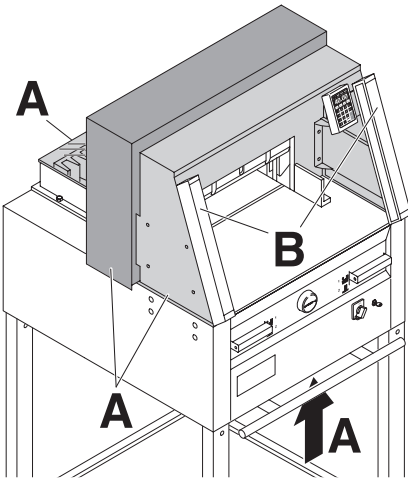

It is forbidden to operate the machine if the operating and safety instructions have not been understood. Please check the safety devices are functioning and complete before use.

- All covers have to be mounted (A).
- Safety beam guard must be mounted (B).
- The release for cutting is allowed only if the two-hand safety device is operated at the same time (C)
- **Safety light beam:**
The machine stops immediately if anyone reaches into the cutting area (D).



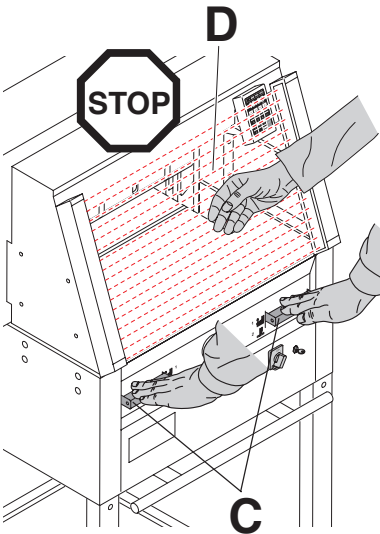

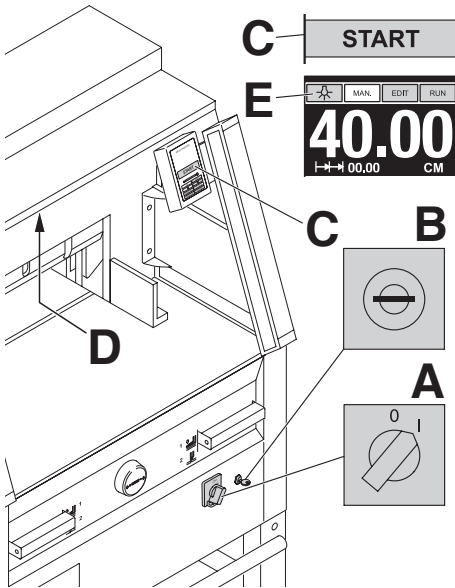
We recommend you keep a record of your test results.





Position the main switch to "I" (A). Insert the key for the control system and move it to the right (B). The machine is now ready for use.

Press START (C).
Machine will automatically go to the start position.

Bright LEDs illuminate the working area (D).
The LED button (E) has 4 switching steps
Press 1 x  → brightness 3
Press 2 x  → brightness 2
Press 3 x  → brightness 1
Press 4 x  → OFF

The light can also be switched off by pressing and keeping pressed the  symbol a few seconds.

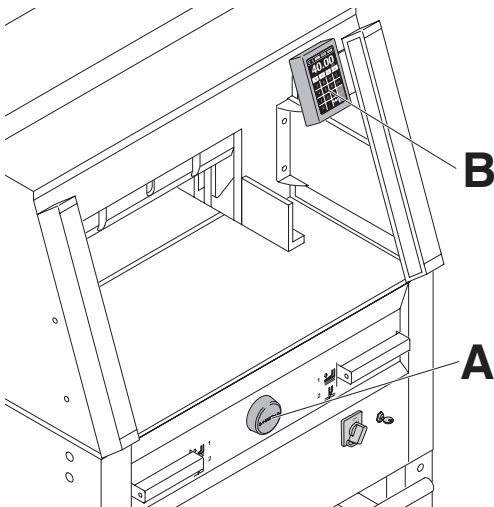

The measurement is set either with the hand-wheel (A) or by programming (B) the cutting measurements. Measurement 2 is shown on the display in inches or cm (B).

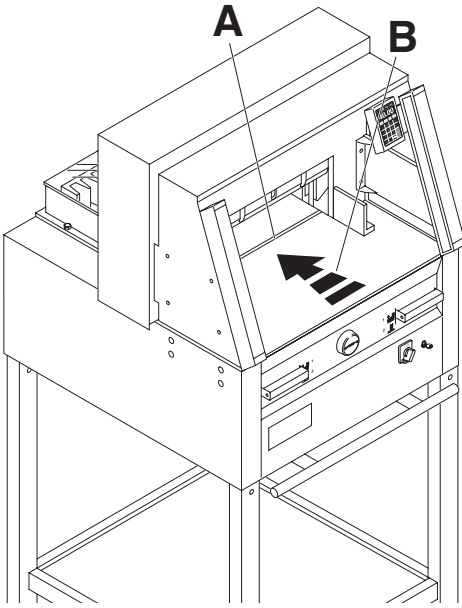

Optical cutting line (A) that indicates the exact position of the cut. Blade cuts on the front edge (B) of the light beam. (Only use when no exact cut is required).

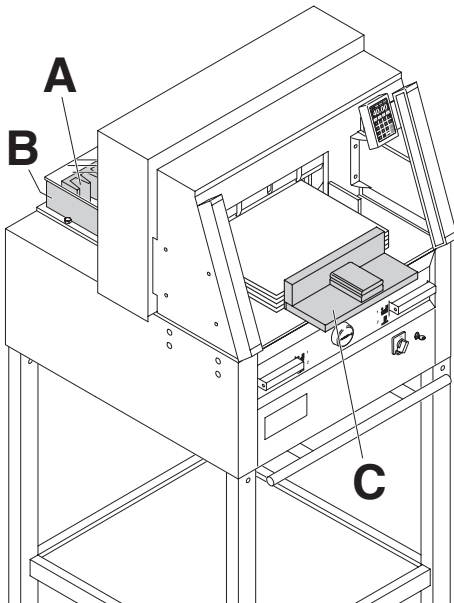

Position the paper on the backgauge (A) and side lays left or right (B). To move paper stacks, please use the paper knock-up block (C) provided. (Run backgauge to the front for turning the paper stack).

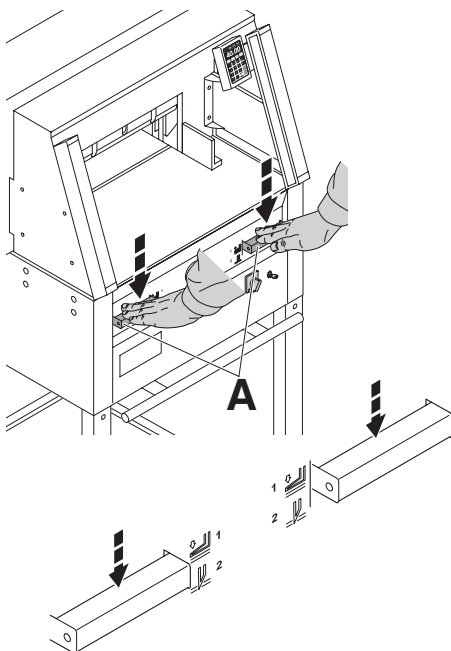

The clamp moves automatically when cutting is activated.

The paper can also be pressed in advance. Clamping and cutting is activated by the actuators (A) on the front table.

The actuator has 2 switching steps:

1. pre-clamping
2. automatic clamping and cutting

Switch position 1



= Pre-clamping
Press down both actuators to step 1



= Clamp returns
Press down completely one of the actuators

Switch position 2



= Cutting sequence with automatic clamping
Press down both actuators to step 2

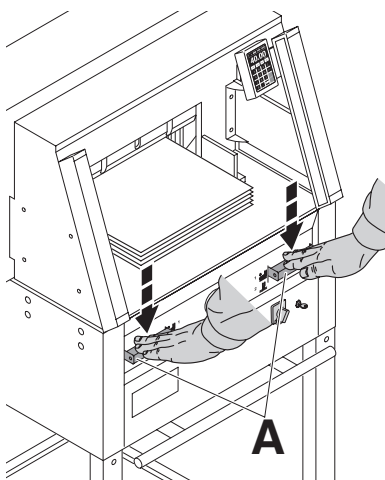

Cutting activation:

Press both actuators of the two-handed control system (A) simultaneously and keep pressed until the paper is completely cut.

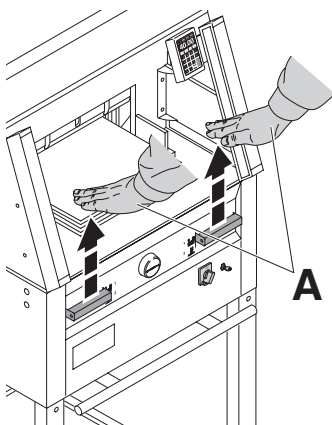

To interrupt or stop cutting:

To interrupt or stop cutting, release both actuators (A) of the two-handed control.

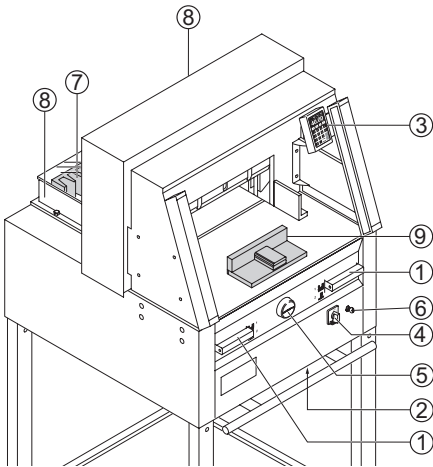

Operating elements

- ① - Safety two-handed control system
Pre-clamping and cutting
- ② - Overload switch
(blade drive/clamp drive/
backgauge drive)
- ③ - Backgauge control
- ④ - Main switch
- ⑤ - Hand-wheel for backgauge setting
- ⑥ - Key switch
- ⑦ - Backgauge
- ⑧ - Side lay left and right

Start machine

- Main switch ④ to position "I", insert the key ⑥ for the control panel and turn to the right. Start screen appears
The following functions are changeable:
Brightness
CM/INCH
Touchtone ON/OFF
Language

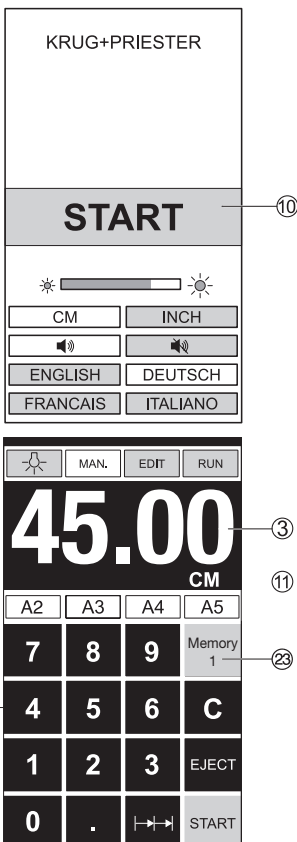

- Press START ⑩ → backgauge ⑦ moves to the rear and searches for the reference position, wait until a measurement is shown in the display ③
IDEAL 4860 = 45.00 cm, 17.72 inches
IDEAL 5260 = 52.00 cm, 20.74 inches
IDEAL 6660 = 61.00 cm, 24.02 inches
- The DIN and free programmable measurements are recallable with the respective buttons ⑭.
Memory 1: A2, A3, A4, A5,
Memory 2: A6, A7, B3, B4
Memory 3:

---	---	---	---
-----	-----	-----	-----

Memory 4:

---	---	---	---
-----	-----	-----	-----

and in inch
Memory 1: 4 1/4", 5 1/2", 7", 8 1/2"
Memory 2: 11", 12", 14", 17"
Memory 3:

---	---	---	---
-----	-----	-----	-----

Memory 4:

---	---	---	---
-----	-----	-----	-----

In memory 3 + 4 (mm and inch) no measurements are saved. Until a first input of data the following will be shown in the corresponding fields:

---	---
-----	-----

. **The measurements entered remain stored. They cannot be deleted but overwritten.**

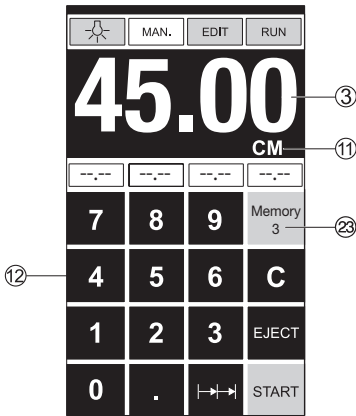

How to program Memory 3 and 4

Press the memory button ⑫ to enter the memory platform (3 or 4). Enter the required measurements or overwrite them. Press the  button and keep it pressed until an acoustic signal sounds, the measurements have been saved now.

Warning!

Before storing or cutting a measurement please check if the correct measurement scale (cm or inch) see above is stored.

For information on how to store see picture below left

Is shown on the screen see ⑪.

After 30 minutes the screen switches to energy-saving mode

The screen is reactivated by touching the keypad area ⑫.

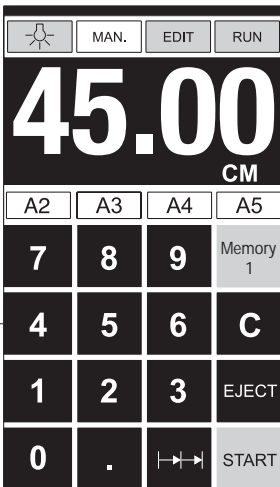
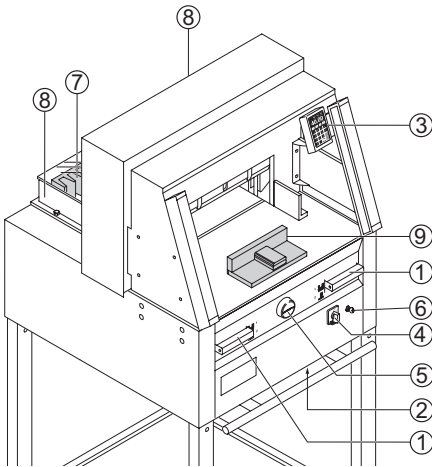

Cutting activation

⚠ Warning!

- Run backgauge to the front for turning the paper stack
- Do not interrupt the upward movement of the blade by performing switching procedures
- Wait until the display is green before activating a cut
- Blade must always be at the top and be covered by the clamp. Do not touch the blade (see safety information on page 35).

⚠ Risk of injury!

Cutting to specified dimensions

- Press **MAN.**
- Enter dimension on the numerical key pad ⑫
→ Measurement is shown in red
(If a wrong dimension is entered this can be corrected by pressing the **C** button)
- Press **START** ⑬ → dimension is approached, → Measurement is shown in green
- Insert paper and move by means of the stacking angle ⑨ to the backgauge ⑦ and side lay on the left ⑧
- Release the cut.

Cut according to markings

- Press **MAN.**
- Adjust the backgauge with the hand-wheel ⑤ to the back
- Insert paper and move by means of the stacking angle ⑨ to the backgauge ⑦ and side lay on the left ⑧
- Turn the hand-wheel ⑤ to the right until the marking on the paper to be cut is below the cutting line indicator
- The further the hand-wheel ⑦ is turned to the right, the quicker the backgauge moves. If the hand-wheel is turned to the left the backgauge will return quicker.

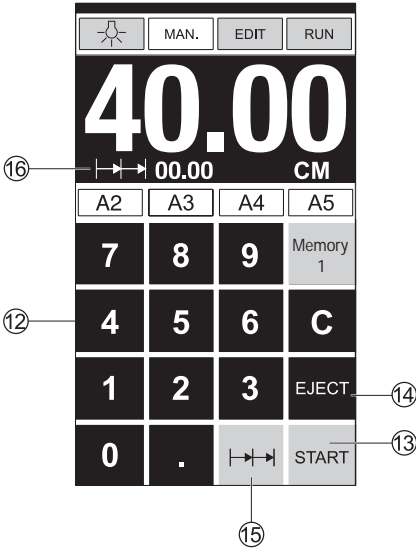

Eject function

If EJECT (14) is pressed instead of START (13), after inserting the measurement (12), the backgauge will advance forwards so that paper can be removed. Finally the backgauge moves to the last setting.

Multiple cut

- Enter the start dimension on the display (12)
- Advance to the measurement with the START (13)
- Push the paper to the backgauge (7)
- Press multiple cut (15)
- Multiple cut sign appears top left together with the value 00.00 (16)
- Enter multiple cut measurement (appears in red letters)
- Press START → the backgauge advances by the multiple cut size
- This is repeated everytime a cut is activated.

Exiting program-mode

- Press multiple cut (15) (yellow). Multiple cut sign and value are deleted.



Programming

This control system enables you to store 99 programs with 99 programmable steps. One step represents one measurement. After entering the program numbers you are able to change between several program steps with the button ∇ and \blacktriangle .

First figure on display ⑰ = program number.
Second figure on display ⑱ = program step.

Smallest cutting measurement:

IDEAL 4860 3.50 cm/1.38 inch

IDEAL 5260 3.50 cm/1.38 inch

IDEAL 6660 2.50 cm/0.98 inch

Each program step corresponds to one dimension. The indicated program step can be overwritten at any time. These programs remain stored when the machine is off.

Entering a program

- Press **EDIT** → "Load program no." appears
- Enter program number 01 ... 99, with \blacktriangle (Top number ⑰ on display = program number)
- If measurement is shown on the display the program is reserved, select another program
- Program step "01 Step" 00.00 ⑱ appears. (Second figure on display ⑱ = program step.)
- Enter dimension, or move the backgauge to the desired measurement with the hand-wheel ⑤
- Store the measurement \blacktriangle , next program step appears.
- Enter the next measurement and with Enter \blacktriangle store the measurement etc.
- Should the entered program be required immediately → press **RUN**
- Press Enter \blacktriangle
- Press START
- Escape the program mode press **MAN.**

Cancel a program

- Press **EDIT**
- Scroll with PRG until "Delete program no." appears
- Enter Program number
- Press Enter \blacktriangle
- Press Enter \blacktriangle .

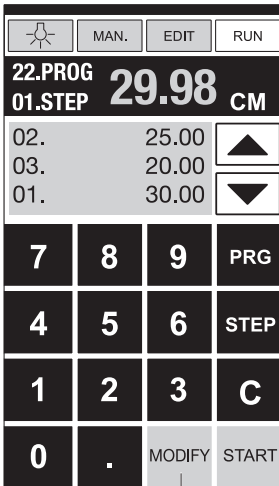

22

Adapting a program when the printer's imprint deviates

- Press **RUN** → "Load program no." appears
- Enter program number 01 ... 99, and with 2 x Enter ↵ proceed to Step 1
- Correct the cutting position of the backgauge with the hand-wheel
- **MODIFY** Ⓜ appears on the screen and the measurement flashes
- To store press **MODIFY**
- Release a cut and turn the paper
- If the printer's imprint deviates it can be corrected during the first two cuts via the hand-wheel – see above
- Correction is only possible during the first two cuts
- After leaving the **RUN** mode the original data is stored again.

Delete a step

- Press **EDIT**
- Enter program number, confirm with Enter ↵
- Select program step with the arrow keys ▲ and ▼
- Scroll with **STEP** until "Delete step no." appears, Press 2 x Enter ↵.

Insert a step

- Press **EDIT**
- Select a program, confirm with Enter ↵
- Scroll with **STEP** until "Insert step no." appears
- Enter insert position e.g. 02
- Confirm with Enter ↵
- Enter a measurement
- Store the measurement with ↵
- The cutting position can be shown on the screen with the arrow keys ▲ and ▼.

Changing a program step

- Press **EDIT**
- Select a program, confirm with Enter ↵
- Scroll with **STEP** until "Load step no." appears
- Enter step position e.g. 03
- Confirm with Enter ↵
- Enter a new measurement, Store the measurement with ↵.

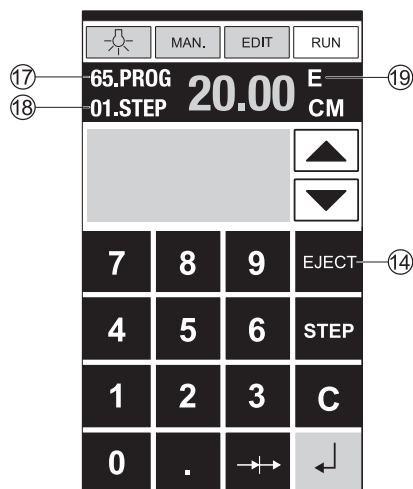

Eject function program

- If a short measurement e.g. 30 cm and then a long measurement e.g. 40 cm is cut at the start of a program then it is wise to insert an EJECT 19 after the first cut so that the paper is pushed to the front.
- The EJECT function can be added each time a measurement is entered and ejects before advancing to the next measurement. When the eject function is programmed an "E" 19 appears top right in the display.
- Inserting an Eject function subsequently in the program. Select a program and advance to the step to be changed with the arrow keys ▲ and ▼ Enter the new measurement and before activating the enter button ↵ press EJECT 14.

Example of a program eject function

- Press **EDIT**
- Enter program number e.g. 08
- Press Enter ↵
- 1. Enter program Step e.g. 30 cm
- Press Enter ↵
- 2. Enter program Step e.g. 40 cm
- Press EJECT and with Enter ↵ store the dimension.

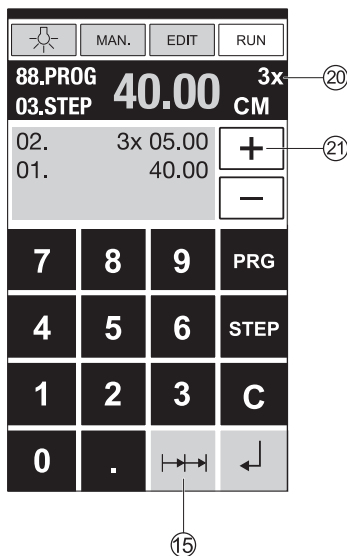

How the example works

- Press **RUN**
- Enter program number 08
- Press Enter ↵
- Press **START**, Measurement is approached
- Insert paper
- Release cut 1
- Eject (Ejection is completed, turn the paper)
- The backgauge moves to program step 2
- Release cut 2

Multiple cut program

- Press **EDIT**
- Enter program number
- Enter the 1. program step e.g. start-up measurement 40 cm
- Store the measurement with Enter ↵
- Press the multiple cut symbol 15
- Enter the number of cuts 20 with the + button 21 (max. 15 cuts) followed by the multiple cut size (cutting width).
- Store with Enter ↵.

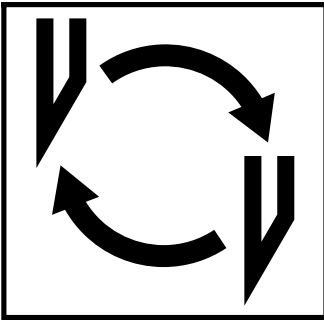

If the cutting quality decreases:

- Check the cutting depth (see page 35).
- Check the cutting stick (see page 31).
- Replace or grind the blade (see page 27 - 35).

The blade cannot be ground if the blade height is less than 83 mm/3,29 inches. A new blade must be used.

The blade may only be ground by a qualified supplier or from the manufacturer Krug & Priester, D-72336 Balingen.

⚠ Danger! Risk of injury!
The blade is extremely sharp. Do not extract or transport the blade without protection. Changing the blade may only be performed by trained staff.

IDEAL 4860 • IDEAL 5260 • IDEAL 6660

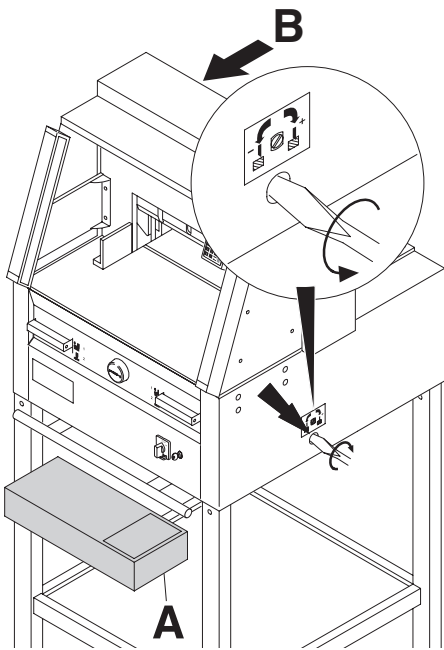

Turn the blade depth adjustment screw to the left until it stops. (Screwdriver found in tool set (A) or tool holder (B).

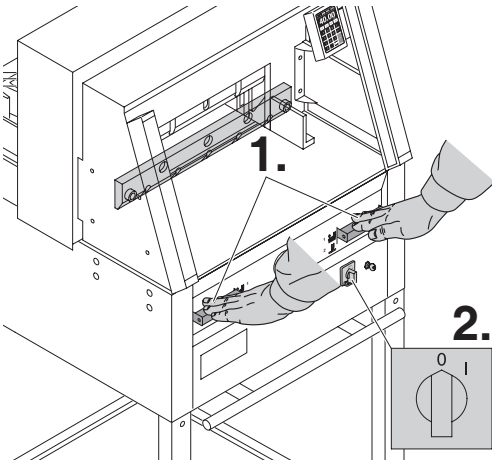

Lower the blade by pressing both cutting actuators (1.). Keep one actuator pressed and turn off the main switch (2.).

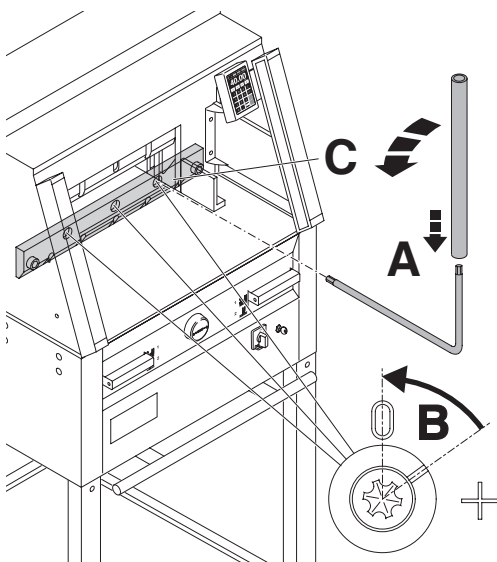

The 3 eccentrics are now exposed and should be turned counter clockwise to position "0" with the special wrench and attachable extension pipe (A) (in the tool set). The slot must correspond to position "0" (B).

Only IDEAL 4860

Unscrew the blade screws (C) on the right hand side.

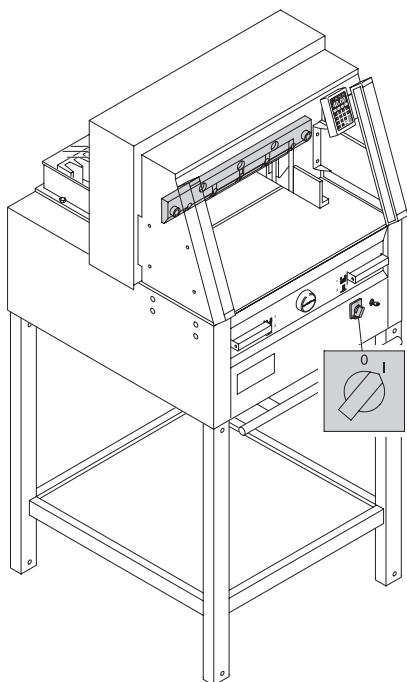

Remove the special wrench and turn on the main switch until the blade returns to the home position.

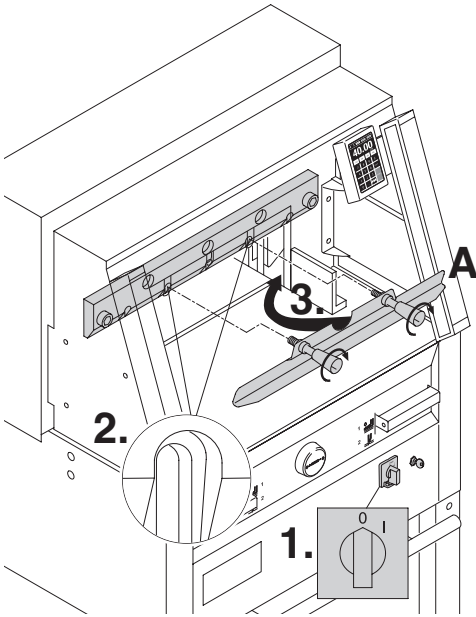

Position the main switch to "0" (1.)
Remove the 2 blade screws on the elongated holes (2.). Then put the blade changing tool (A) into place and fasten it to the blade (3.).

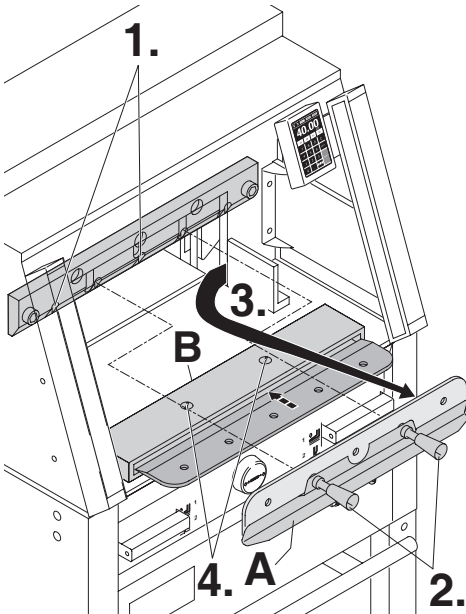

Remove 2 blade screws IDEAL 4860 and 3 blade screws IDEAL 5260, IDEAL 6660 (1.). Loosen the grips (2.) of the blade changing tool (A) lightly and allow the blade to be taken downwards out of the machine (3.). Place the blade into the blade carrier (B) and screw it into place (4.).

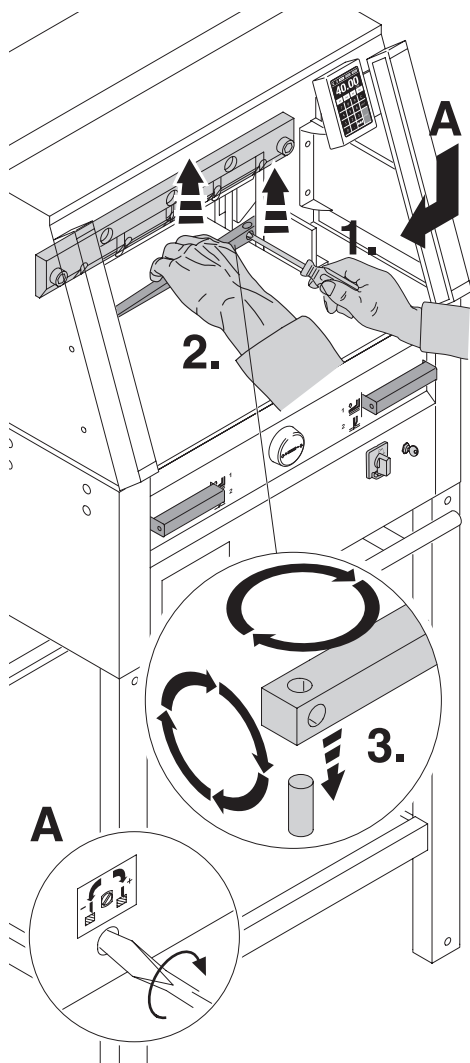

Take out the cutting stick with a small screwdriver. If needed the cutting stick can be turned or exchanged. (The cutting stick can be used eight times).

Replacing the cutting stick (not the blade).

- Turn the blade adjusting screw (A) to the left until it stops. (Otherwise the first cut will be too deep).
- Remove the cutting stick according to top picture.
- Turn the cutting stick (the non-used side must be near to the blade) and plug it into the holding bolt.

⚠ Danger! Risk of injury!

Cutting test after replacing the cutting stick (not the blade)

- Insert the paper and release the cut.
- If the last sheet of paper is not cut along the entire length turn the blade adjusting screw (A) $\frac{1}{4}$ turn to the right.
- If the last sheet is still not completely cut repeat this process until the last sheet is cut along the entire length.

IDEAL 4860 • IDEAL 5260 • IDEAL 6660

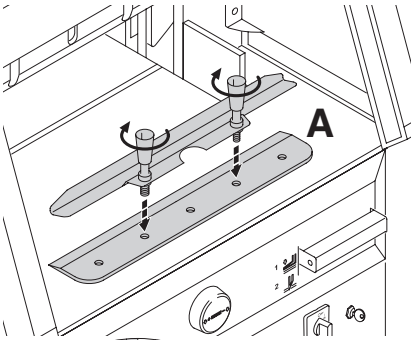

Take the exchange blade carefully out of the blade box and screw it to the blade changing tool (A).

- Make sure there is a space of 11 mm or 0.43 inches! (B).
- Blade must be covered! (C).

⚠ **Danger! Risk of injury!**

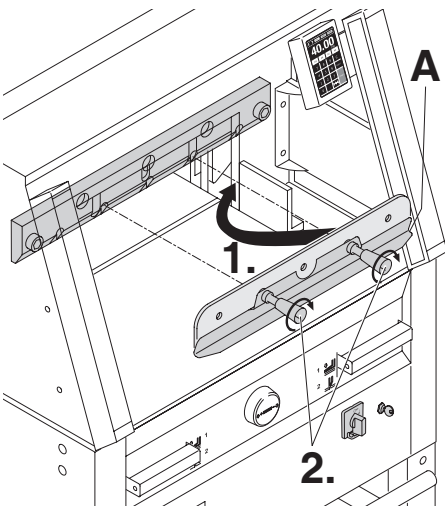
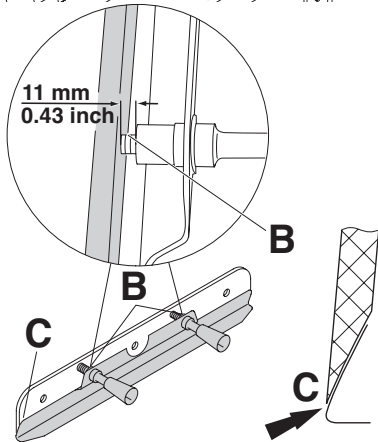

Place the blade to be exchanged with the blade changing tool (A) mounted (1.), into the blade carrier and push it up to the top and screw it into place with the grips (2.).

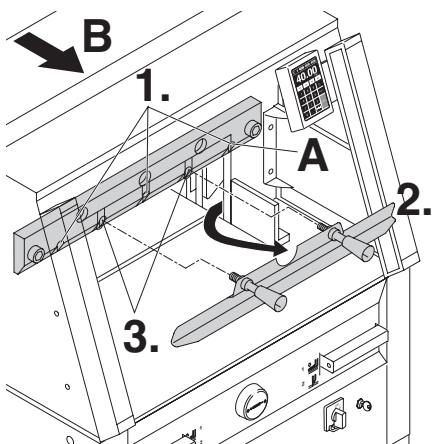

Lightly tighten 3 (IDEAL 4860 has 2) of the 5 blade screws with washers (1.). Remove the blade changing tool (2.). Lightly tighten the remaining blade screws with washers (3.). Return blade changing tool to tool holder (B).

Only IDEAL 4860

Lightly screw in the right blade screw with the washer (A) when the blade is lowered.

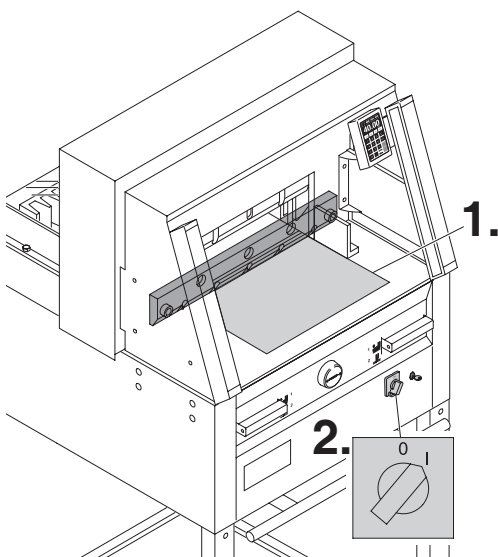

Remove all tools and distribute paper along the entire cutting length (1.). Turn main switch to position "I" (2.).

IDEAL 4860 • IDEAL 5260 • IDEAL 6660

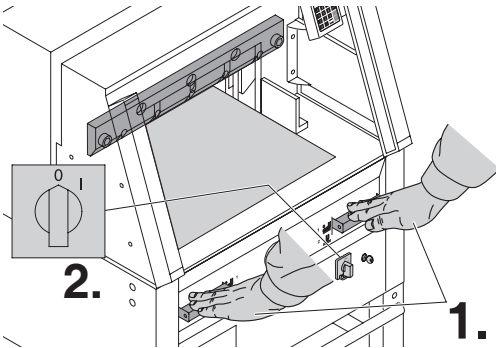

Lower the blade by pressing both cutting buttons (1.). Keep one button pressed and turn off the main switch (2.).

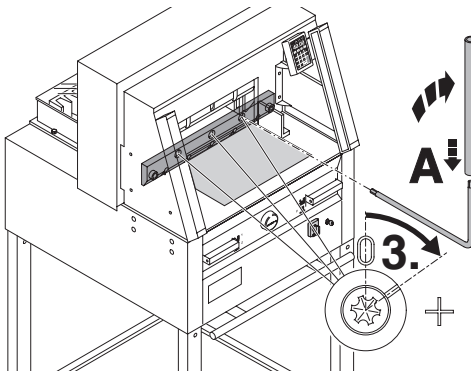

With the special wrench (A) the 3 eccentrics should be screwed down (3.) until the paper is cut along the entire length of the blade (The blade must remain parallel, not too deep into cutting stick).

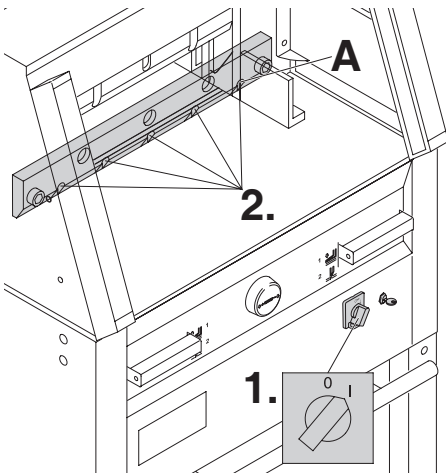

Only IDEAL 4860

Tighten the blade screws (A) on the right hand side.

Turn main switch to position "I" (1.). Blade will return to upper position. Tighten the blade screws (2.) firmly.

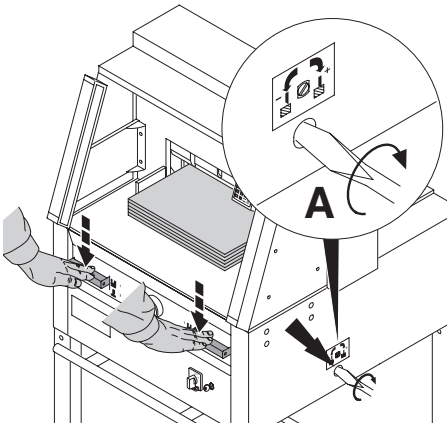

Paper cutting test. If the last sheet or several sheets are not completely cut, gradually turn the knob for blade depth adjustment (A) $\frac{1}{4}$ turn to the right until the paper is cut along the entire length. Do not set too low as blade will become blunt sooner.

⚠ Danger by blade replacement!
Blade must always be covered by the pressing bar (see picture below at the left).

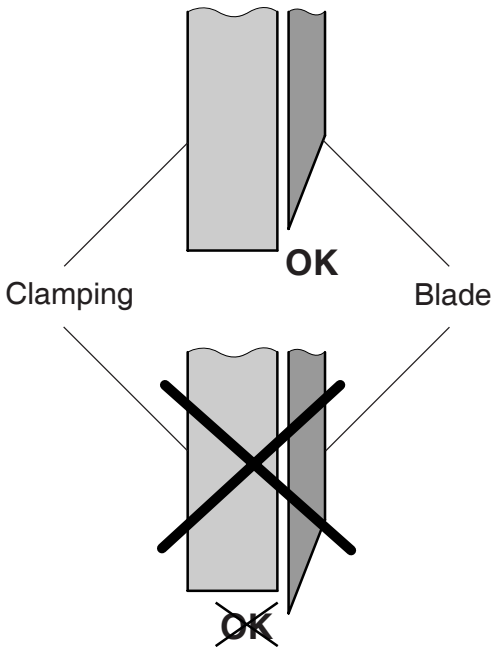

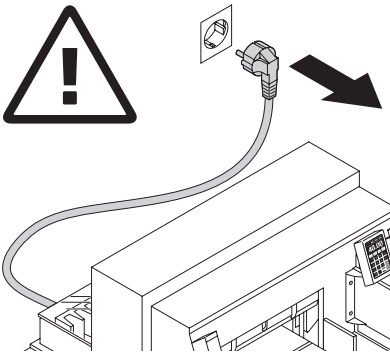

⚠ Danger! Disconnect the mains before starting any service work or before removing the cover.

Maintenance work may only be performed by trained staff.

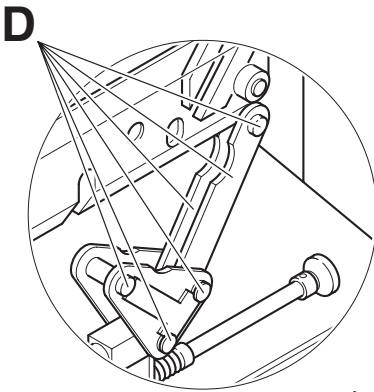

Grease the backgauge (A) control weekly with a grease gun. Advance the backgauge as far as possible to the front. (Use non-resinous oil or grease).

Grease the remaining parts twice a year (see picture).

The main switch must be on "0" (B).

Remove lower panel (C).

Tools in tool set or tool holder.

- Remove any paper.
- Grease the machine.
- Check the 4 joining bolts and 2 pushing bars for wear (D). If necessary inform your service personnel.
- Mount the machine.

 = Greasing points on the machine.

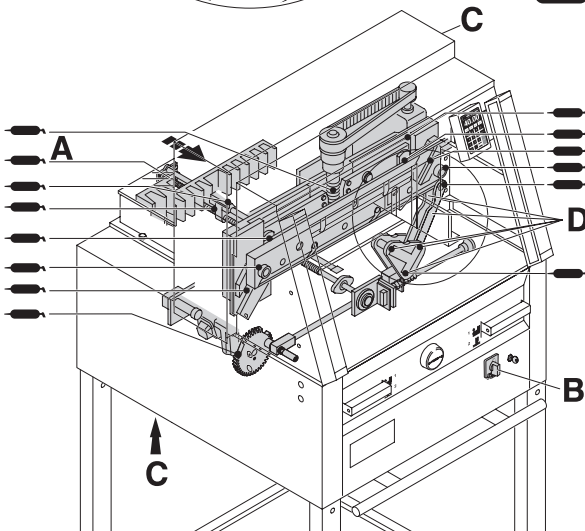

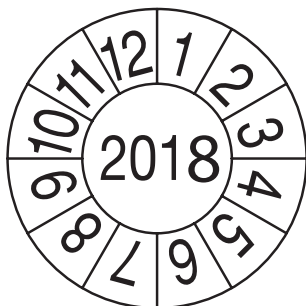

Safety test

The safety regulations are according to the regulations of the country where the cutting machine is operated. The manufacturer recommends a safety check is made every 5 years by an authorised service team.



Machine does not function!

Is the machine plugged in?

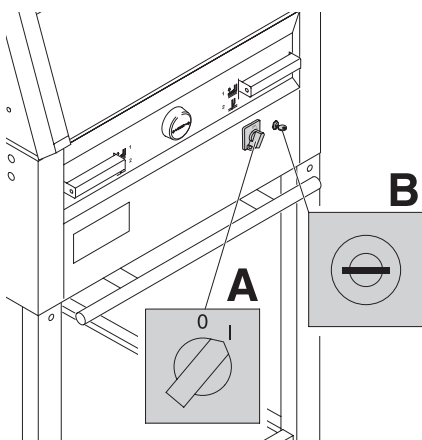
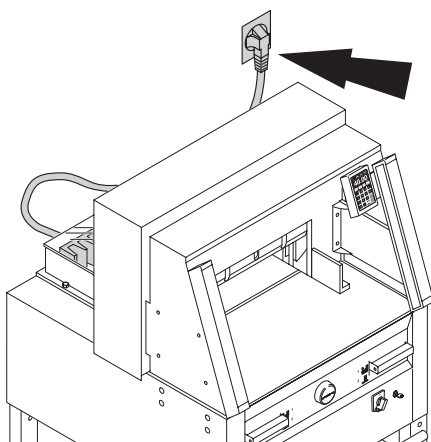

Main switch to position "I"? **(A)**
Control system activated? **(B)**
(Turn key to the right)
Release a cut see page 19.

• Possible malfunctions •

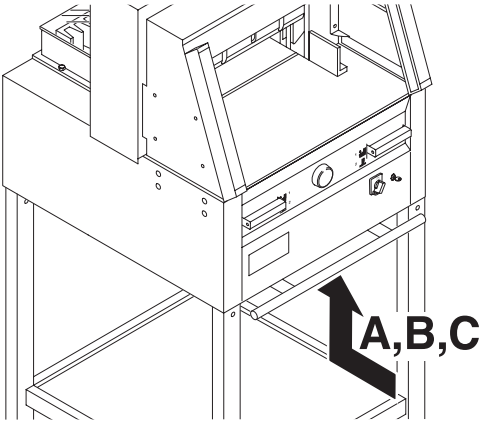

Machine turns off:

- Machine overloaded.
Safety button (A) or (B) ejects.
(Allow 1 minute cooling time and reset the safety button (A) or (B).
- Machine blocked.
Blade is blunt.
Eliminate the cause, and push the safety button (A).
- Backgauge blocked
Safety button (C) ejects.
Eliminate the cause, and push the safety button (C).

Safety button for:



A = Blade drive

B = Clamping drive

C = Backgauge drive

IDEAL 4860 • IDEAL 5260 • IDEAL 6660

A

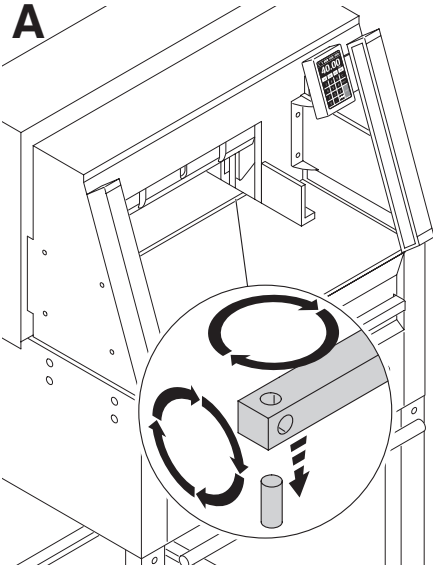

Does not cut through the last sheet:

- Turn or turn around the cutting stick (A), readjust the blade by means of the blade adjusting knob (B) (see page 35).

Poor cutting quality or blade stays in the paper stack.

- Change the blade (C) (see pages 27 - 35).

B

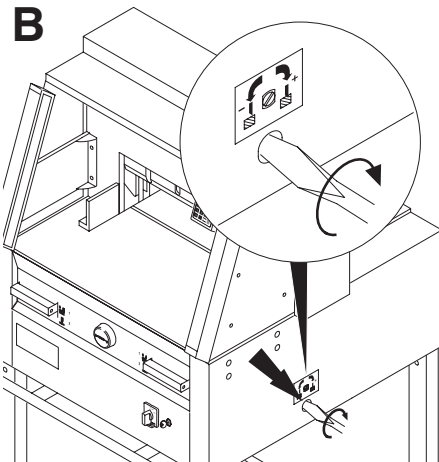

C

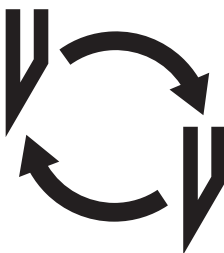

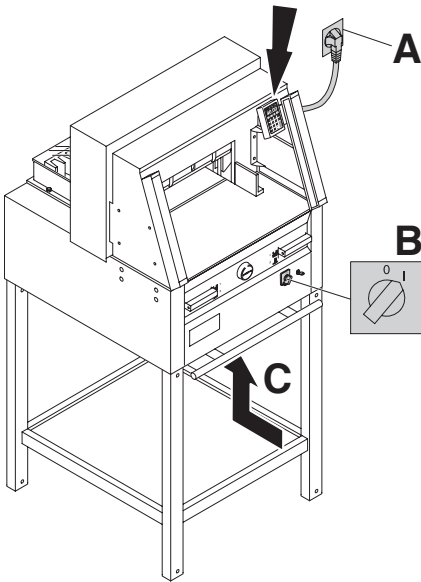

Display illumination off

- Machine is plugged in? (A)
- Main switch on position "I"? (B)
- Push in the safety button! (C)
- Check the units fuse and the on-site circuit breaker!

After 30 minutes the screen switches to energy-saving mode

The screen is reactivated by touching the keypad area ⑫.

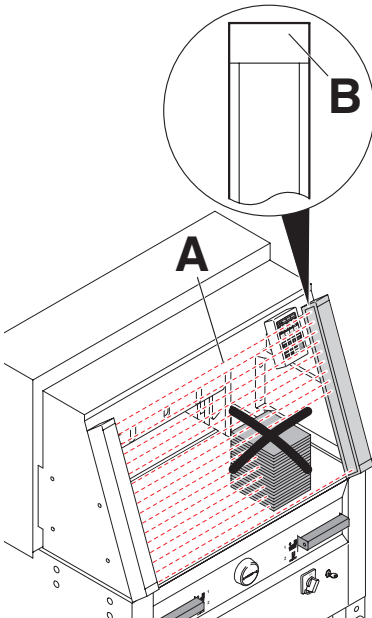

Trouble shooting-light beam

Cut cannot be activated:

- Remove all items obstructing the safety area (A)
- Only the receiver (right-hand) has a display (B)
Green = ready for operation
Red = light beam is interrupted or error

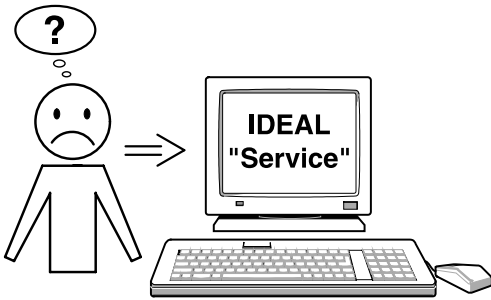

Motor runs but blade does not move downwards.

- Security brake has been activated!
Inform the Service Team!

None of the above mentioned methods helped to solve the problem:

Contact Service Team under

- www.ideal.de → "Service"
service@krug-priester.com

Recommended accessories:

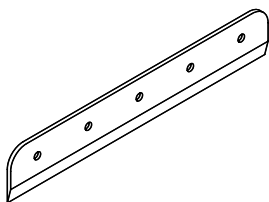

Blade

- Nr. 9000 021 IDEAL 4860
- Nr. 9000 130 IDEAL 5260
- Nr. 9000 025 IDEAL 6660

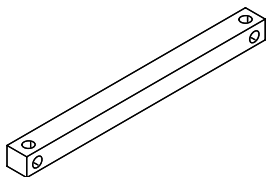

Cutting stick (6 pieces)

- Nr. 9000 022 IDEAL 4860
- Nr. 9000 024 IDEAL 5260
- Nr. 9000 026 IDEAL 6660

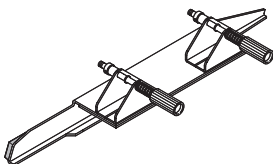

Blade changing tool ¹

- Nr. 9000 518 IDEAL 4860
- Nr. 9000 512 IDEAL 5260
- Nr. 9000 513 IDEAL 6660

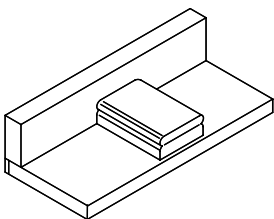

Paper knock-up block ¹

- Nr. 9000 521

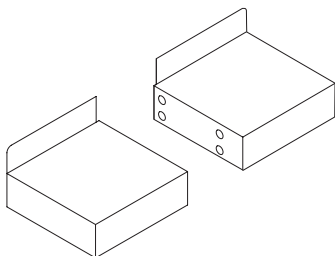

Side tables left and right

- Nr. 9000 528

¹ Included in delivery

IDEAL 4860 • IDEAL 5260 • IDEAL 6660

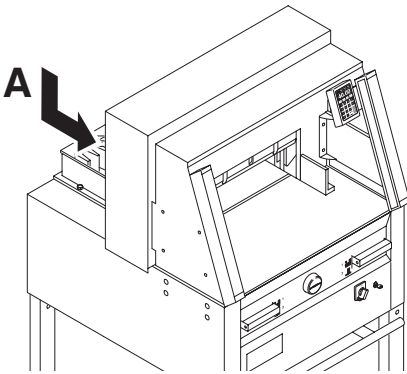

Technical data:

- Power supply: 230V/50Hz/1~, 120V/60Hz/1~
- Cutting height: 80 mm
- Leakage current < 3,5mA
- Power cord gauge min. 1,5mm² (230V)
- Power cord gauge AWG 12 (20A) (120V)

The exact technical specifications can be found on the technical specifications sticker (A) on the machine. A wiring diagram is found in the electrical switch box.

To claim under guarantee, the machine must still carry its original identification label.

Safety light beam

- Total reaction time: 97 ms
- Resolution 14 mm/minimum distance: 194 mm
- Resolution 25 mm/minimum distance: 286 mm

Ambient operating temperature 10 °C - 60 °C

Air humidity (not condensating) 15 % - 95 %

	Cutting-length mm	Table-depth mm	Minimum space requirement (B X T X H) mm	Weight kg
IDEAL 4860	475	450	765* x 1000** x 1300	232***
IDEAL 5260	520	520	865* x 1135** x 1295	249***
IDEAL 6660	650	610	1000* x 1230** x 1295	312***

* with side tables: (Width)

IDEAL 4860 1365 mm

** with side tables: (Depth)

IDEAL 4860 1020 mm

* with side tables: (Width)

IDEAL 5260 1465 mm

** with side tables: (Depth)

IDEAL 5260 1155 mm

* with side tables: (Width)

IDEAL 6660 1600 mm

** with side tables: (Depth)

IDEAL 6660 1250 mm

*** with side tables: IDEAL 4860, 241 Kg

*** with side tables: IDEAL 5260, 257 Kg

*** with side tables: IDEAL 6660, 321 Kg



This machine is approved by independent safety laboratories and is in compliance with the EC-regulations 2006/42/EG and 2004/108/EG.

Sound level information:

Sound measurement to EN 13023 :
72,5 db (A)



Subject to alteration without notice.



I.T.E. Listed 802 D



Krug + Priester has a certified quality management system according to DIN EN ISO 9001:2008 and a certified environmental management system according to DIN ISO 14001:2009.



DE EG-KONFORMITÄTSERKLÄRUNG
EN EC-declaration of conformity
FR Déclaration de conformité CE

- **Hiermit erklären wir, daß die Bauart von**
- Herewith we declare that
- Par la présente, nous déclarons que

4860	GS-ID Nr. 11486001	UL-ID Nr. 10486001
5260	GS-ID Nr. 11522102	UL-ID Nr. 10522102
6660	GS-ID Nr. 11655002	UL-ID Nr. 10655002

- **folgenden einschlägigen Bestimmungen entspricht**
- complies with the following provisions applying to it
- sont conformes aux dispositions pertinentes suivantes

2006/42/EG:

Maschinenrichtlinie, EC Machinery directive, EC Directives machines.

2004/108/EG:

EMV Richtlinie, EMV Electromagnetic compatibility directive,
EMV directives compatibilité électromagnétique.

2011/65/EU

RoHS Richtlinie, RoHS directive, RoHS directives.

- **Angewendete harmonisierte Normen insbesondere**
- Applied harmonised standards in particular
- Normes harmonisées utilisées, notamment

EN 60204-1; EN 1010-1; EN 1010-3; EN 55014-1; EN 55014-2;
EN 61000-3-2; EN 61000-3-3; EN ISO 12100; EN 61496-1; EN 61496-2;
EN ISO 13857; EN ISO 11204; EN 13023; EN ISO 13849-1

01.06.2013

Datum



- Geschäftsführer-

Bevollmächtigter für technische Dokumentation
Authorized representative for technical documentation
Représentant autorisé pour la documentation technique

Krug & Priester GmbH u. Co KG
Simon-Schweitzer-Str. 34
D-72336 Balingen (Germany)

• Document Shredders •



• Trimmers and Guillotines •

